

भारतीय मानक

छत के लिए मिट्टी की टाइलें मंगलौर नमूने — विशिष्ट

(तीसरा पुनरीक्षण)

Indian Standard

CLAY ROOFING TILES, MANGALORE
PATTERN — SPECIFICATION

(*Third Revision*)

UDC 666.74

© BIS 1992

BUREAU OF INDIAN STANDARDS
MANAK BHAVAN, 9 BAHADUR SHAH ZAFAR MARG
NEW DELHI 110002

FOREWORD

This Indian Standard (Third Revision) was adopted by the Bureau of Indian Standards, after the draft finalized by the Clay Products for Buildings Sectional Committee had been approved by the Civil Engineering Division Council.

Clay roofing tiles of interlocking type, a particular pattern of which is known as Mangalore pattern in the trade, are being manufactured in large scale in southern part of this country. The provision in regard to the minimum quality requirements of these tiles was provided in this standard which was first published in 1957 and revised in 1962. This second revision in 1972 contained provision in regard to the uniformity in colour and also the actual sizes of tiles. In this third revision, an alternate method to determine breaking load of the tile has been included apart from incorporating amendments to the standard so far.

The Sectional Committee responsible for the preparation of this standard has taken into consideration the views of producers, consumers and technologists and has related the standard to the manufacturing and trade practices followed in the country in this field.

For the purpose of deciding whether a particular requirement of this standard is complied with, the final value, observed or calculated, expressing the result of a test, shall be rounded off in accordance with IS 2 : 1960 'Rules for rounding off numerical values (*revised*)'. The number of significant places retained in the rounded off value should be the same as that of the specified value in this standard.

Indian Standard

CLAY ROOFING TILES, MANGALORE PATTERN — SPECIFICATION

(Third Revision)

1 SCOPE

This standard covers the specification of machine-pressed clay interlocking roofing tiles of the 'Mangalore Pattern'.

2 REFERENCES

The Indian Standard is a necessary adjunct to this standard.

IS No.	Title
IS 2248 : 1991	Glossary of terms relating to structural clay products (<i>second revision</i>).

3 TERMINOLOGY

For the purpose of this standard, the definition of terms given in IS 2248 : 1991 shall apply.

4 CLASSIFICATION

Roofing tiles, Mangalore Pattern, shall be of two classes, namely Class AA and Class A and shall be classified as per the characteristics as specified in Table 1.

5 GENERAL QUALITY

5.1 The roofing tiles shall be made from suitable clay of even texture and shall be well burnt. They shall be free from irregularities, such as twists, bends, cracks and laminations.

5.2 The roofing tile shall be free from impurities like particles of stone, lime or other foreign materials visible to the naked eye either on the surface or on the fractured face of the tile obtained by breaking the tile. However, occasional particles up to 2 mm in size may be permissible. When struck, the tile shall give a characteristic ringing sound and when broken the fracture shall be clean and sharp at the edges. The Class AA tile shall be of uniform colour.

5.3 Shape

When the roofing tile is placed on either face on a plane surface, the gap at the corners shall be not more than 6 mm.

5.4 Lugs

5.4.1 Batten Lugs

The tile shall have at least 2 batten lugs with base thickness (thickness at bottom) not less than 15 mm and thickness at top not less than 10 mm. The projection from surface of the tile shall be between 7 and 12 mm (*see Fig. 1*).

5.4.2 Eave Lugs

The tile shall be at least 2 eave lugs with base thickness not less than 15 mm and thickness at top not less than 10 mm. The projection from surface of lug shall be not less than 10 mm and shall be shaped to fit into the corrugations (*see Fig. 1*).

5.5 Corrugations and Cross Ribs

The cross section of the roofing tile shall be such as to give the tile structural rigidity. This may be achieved by providing longitudinal corrugations with intermediate cross ribs or stiffeners (*see Fig. 1*).

5.6 Tie Down Hole

At least one hole shall be provided in one of the cross ribs near the eave end of the tile for securing the tile to the reeper or batten with wire. The hole shall be clear and true and shall be not more than 2 mm in diameter, but shall be large enough to pass a 1.6 mm wire easily (*see Fig. 1*).

Table 1 Classification of Roofing Tiles
(*Clauses 4.1, 7.5.3, 7.5.4, 8.1 and 8.3*)

SI No.	Characteristic	Requirement	
		Class AA	Class A
i)	Water absorption percent, <i>Max</i>	18	20
ii)	Breaking load, kN, <i>Min</i> :		
		a) Average	1.0 (for 410 × 235 mm) 1.10 (for 420 × 250 mm and 425 × 260 mm)
	b) Individual	0.90 (for 410 × 235 mm) 1.00 (for 420 × 250 mm and 425 × 260 mm)	0.68 (for 410 × 235 mm) 0.78 (for 420 × 250 mm and 425 × 260 mm)

6 DIMENSIONS AND TOLERANCES

6.1 Dimensions

There shall be three sizes of tiles, with principal dimensions as given in Table 2. The tolerances in length and width are given in 6.2.

Table 2 Dimensions of Tiles

Sl No.	Overall Length	Overall Width
(1)	(2)	(3)
	mm	mm
i)	410	235
ii)	420	250
iii)	425	260

NOTE — If the maximum overlaps are kept, the tile at Sl No. (i) is used for batten spacing up to 320 mm, Sl No. (ii) up to 350 mm and Sl No. (iii) up to 360 mm. However by reducing suitably overlaps in the tiles at Sl No. (i) and (ii) these can also be used for batten spacing up to 350 and 360 mm.

6.1.1 The minimum overlap (see Fig. 1) shall be 60 mm lengthwise and 25 mm widthwise for each type of tiles.

6.2 Tolerances

For measurement of variations in length/width of tiles the difference between:

- a) the overall length/width of three tiles (measured in accordance with 6.2.1), and
- b) the length/width of a tile;

is calculated and this value shall be within the limits mentioned below:

For Tile Sizes	Value for Length	Value for Width
mm	mm	mm
410 × 235	630 to 650	410 to 430
420 × 250	670 to 690	420 to 440
425 × 260	690 to 710	430 to 450

6.2.1 Three tiles shall be selected at random from the sample selected under 7.3. All blisters, loose particles of clay and small projections shall be removed. These shall be arranged upon a level surface interlocked along length/widthwise on straight line in tight position, and overall dimensions are measured (see Fig. 2).

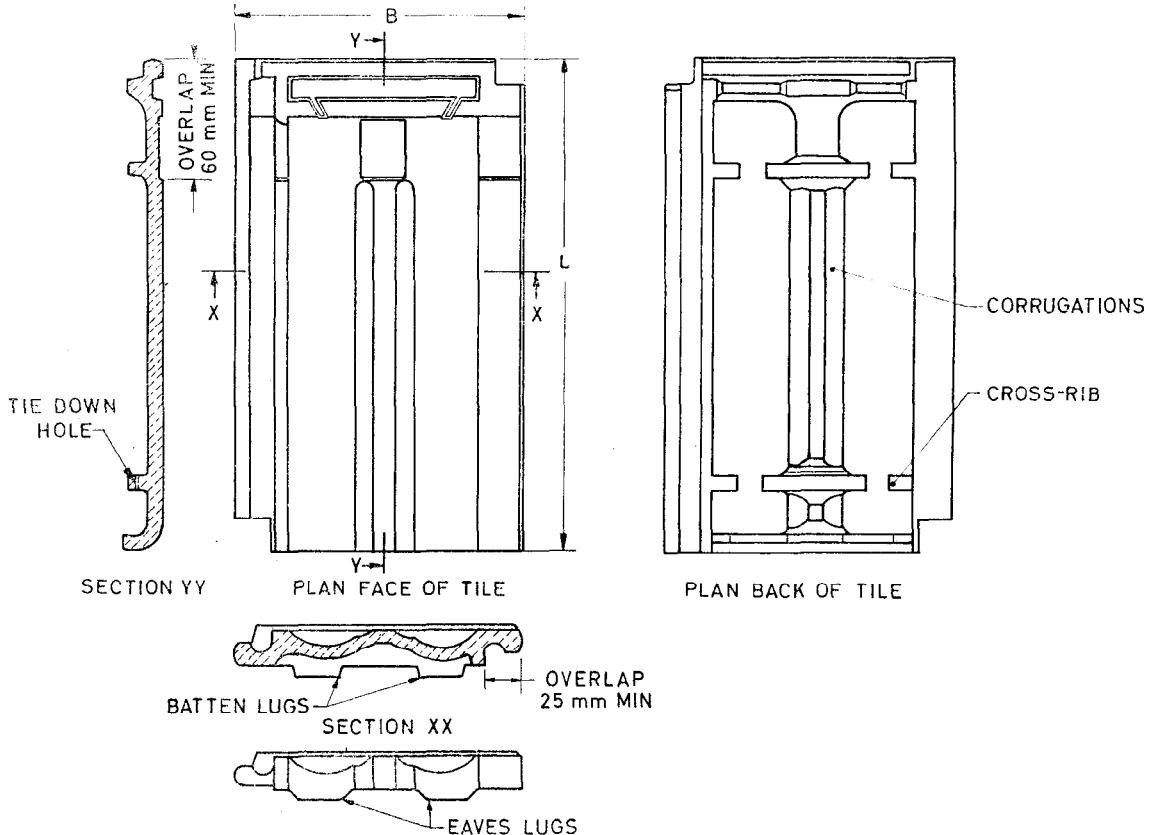
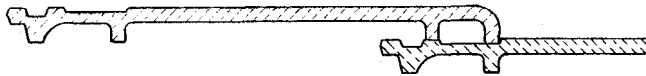

FIG. 1 TYPICAL DETAILS OF MANGALORE TILE



2A ARRANGEMENT OF THREE TILES
LENGTHWISE IN TIGHT POSITION



2B ARRANGEMENT OF THREE TILES
BREADTHWISE IN TIGHT POSITION
FIG. 2 MEASUREMENT OF TOLERANCES

6.3 Weight

The average weight of the six tiles, when dried at 105 to 110°C to constant weight and weighed, shall be not less than 2 kg and not more than 3 kg.

6.3.1 The weight of tile shall be noted correct to the nearest 0.01 kg.

7 SAMPLING

7.1 The sample for testing shall be taken by the purchaser or his representative or by any person appointed to superintend the works for the purpose of which the tiles are required or by the latter's representative.

7.2 Lot

In any consignment all the tiles of the same class and size and from the same batch of manufacture shall be grouped into a minimum number of lots of 50 000 tiles or part thereof.

7.3 The number of tiles to be selected at random from the lot shall depend upon its size and shall be in accordance with col 1 and 2 of Table 3.

7.4 Number of Tests

7.4.1 All the tiles selected as in 7.3 shall be examined for shape (see 5.3), dimensions (see 6) and weight (see 6.3).

Table 3 Sample Size and Criterion for
Conformity
(Clause 7.3)

Lot Size	Sample Size	Permissible Number of Defective Tiles
(1)	(2)	(3)
Up to 3 000	32	3
3 001 to 10 000	50	5
10 001 to 35 000	80	7
35 001 and above	125	10

7.4.2 Eighteen tiles shall be selected out of those already examined as in 7.4.1, six each for water absorption test, breaking load test and permeability test (see 8).

7.5 Criteria for Conformity

7.5.1 The lot shall be considered as conforming to the requirements of the specification if the conditions mentioned under 7.5.2 to 7.5.5 are all satisfied.

7.5.2 The number of tiles failing to satisfy the requirements of any of the characteristics mentioned in 7.4.1 shall not exceed the corresponding number given in col 3 of Table 3.

7.5.3 From the test results for water absorption, the average (\bar{x}) and range (R) shall be calculated. The value of the expressing ($\bar{x} + 0.5 R$) shall be less than or equal to the corresponding limit given in Table 1.

7.5.4 All the individual values of breaking load shall be above the corresponding minimum value specified for individual in Table 1. The average of the six test results shall be above the corresponding minimum limit specified for the average in Table 1.

7.5.5 In the case of permeability test all the tiles tested for permeability shall satisfy the requirements of the test.

8 STRENGTH REQUIREMENTS

8.1 Water Absorption Test

The water absorption of tiles shall conform to the requirements laid down in Table 1, when determined in accordance with the procedure laid down in Annex A.

8.2 Permeability Test

The tiles shall also be tested for permeability, if so specified by the purchaser, in accordance with the procedure laid down in Annex B.

8.2.1 The tiles shall be considered as satisfying the test, if no water dripping is found at the bottom of the tile after the test.

8.3 Breaking Load Test

The breaking load of tiles shall conform to the requirements laid down in Table 1, when determined in accordance with the procedure laid down in Annex C.

9 NON-COMPLIANCE WITH TESTS

If any of the roofing tiles in the samples fails to comply with the requirements of any of the tests specified in 8 another sample shall be similarly drawn and tested. If any of the tiles in the second sample also fails to comply with the

requirements of tests specified in 8 then the whole lot from which the samples were taken be rejected as not complying with this standard.

10 MARKING

10.1 Each roofing tile shall be legibly and indelibly marked with the name of the manufacturer or his trade-mark, if any; the marking shall not cover more than five percent of the area of the specimen.

10.1.1 Each roofing tile may also be marked with the Standard Mark.

ANNEX A
(Clause 8.1)

WATER ABSORPTION TEST

A-1 TEST SPECIMEN

A-1.1 Six tiles shall be used for this test from the sample selected in the manner given under 7.

A-2 PROCEDURE

A-2.1 Dry the six tiles selected in an oven at a temperature of 105 to 110°C till they attain constant weight and then cool and weigh. When cool, immerse the dry specimens completely in clean water 24 to 30°C for 24 h. Remove each specimen, wipe off the surface water carefully with a damp cloth and weigh the specimen. Weigh the specimen nearest to a grain within three minutes after removing the specimen from the tank.

A-3 EVALUATION AND REPORT OF TEST RESULTS

A-3.1 The percentage water absorption shall be calculated using the following formula:

$$\text{Percentage absorption} = \frac{B - A}{A} \times 100$$

where

- B* = weight of the specimen after 24 h immersion in cold water, and
- A* = weight of the dry specimen.

A-3.2 The average percentage water absorption of the six tiles shall be calculated and reported as the percentage water absorption.

ANNEX B
(Clause 8.2)

PERMEABILITY TEST

B-1 TEST SPECIMEN

B-1.1 Six tiles shall be used for this test from the sample selected in the manner given under 7.

B-2 APPARATUS

B-2.1 The test shall be conducted in a rectangular trough (see Fig. 3) which is open at bottom, the dimensions at bottom being equal to the size of the Mangalore Pattern tile. When the tile is kept against its bottom, it shall be held in position and the fitment shall facilitate easy plugging of the space between the edges of the tiles against leakage of water.

B-3 TEST PROCEDURE

B-3.1 The test shall be conducted at temperature of 27 ± 2°C and relative humidity of 65 ± 5 percent.

B-3.2 The tile shall be fitted at the bottom of the trough and the space between the tile and the

sides of the trough plugged water-tight with a suitable material like wax, bitumen, etc.

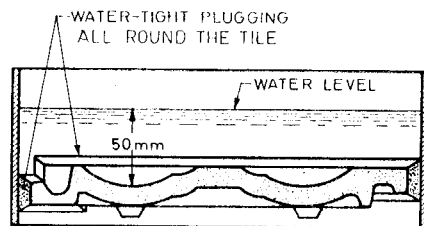

FIG. 3 ARRANGEMENTS FOR PERMEABILITY TEST

B-3.2.1 Water shall be poured into the mould so that it stands over the lowest tile surface to a height of 5 cm.

B-3.3 The water in the trough shall be allowed to stand for a period of six hours. The bottom of the tile shall then be carefully examined to see whether the water has seeped through the tile.

ANNEX C

(Clause 8.3)

DETERMINATION OF BREAKING LOAD

C-1 TEST SPECIMEN

C-1.1 Six tiles shall be used for this test from the sample selected in the manner as given under 7.

C-2 APPARATUS

C-2.1 The apparatus (see Fig. 4) shall consist of two parallel self-aligning cylindrical steel bearers, with the bearing surface rounded to 40 mm diameter, so placed that the distance between the centres could be altered. The load is applied through a third steel bearer of similar shape placed midway between and parallel to the supports. The length of all the bearers shall exceed the maximum width of the tile under test.

C-2.1.1 The loading device may consist of a bucket connected either directly or through levers to the loading arms. The loading shall be at a uniform rate of 450 to 550 N/min by allowing lead shots to flow into the bucket. Provision shall be made to arrest the flow of lead shots immediately the tile breaks.

C-2.2 Alternatively, a suitably modified hand operated compression testing machine with a minimum load frame capacity of 10 tons may be used (see Fig. 5). In this system the bearer assembly is mounted on a rigid mild steel plate and the third central loading bearing is fixed

through a suitable dial micrometer (least count 0.25 mm) or an equally Sensitive devise to bear on the loading member or on the specimen at mid span. The specimen is supported on the bottom parallel bearers separated by a distance of minimum three-fourths (3/4) of the length of the tile.

C-2.2.1 The error in the load reading shall not exceed 2.2 N for loads upto 220 N and for greater load, the error shall not exceed 1 percent of the maximum load. The rate of loading should be uniform and vary in the range of 450-550 N/min (45 to 55 kg/min).

C-3 PROCEDURE

C-3.1 Test, six tiles after soaking them in water at $27 \pm 2^\circ\text{C}$ for 24 h, in the wet condition. Support the tile evenly flatwise on the bearers set with a span of 25 cm and resting on the bottom surface. Apply the load with the direction of the load perpendicular to the span, at a uniform rate of 450 to 550 N/min.

C-4 EVALUATION AND REPORT OF TEST RESULTS

C-4.1 The individual breaking load of each of the six tiles separately in wet condition shall be recorded and the average calculated.

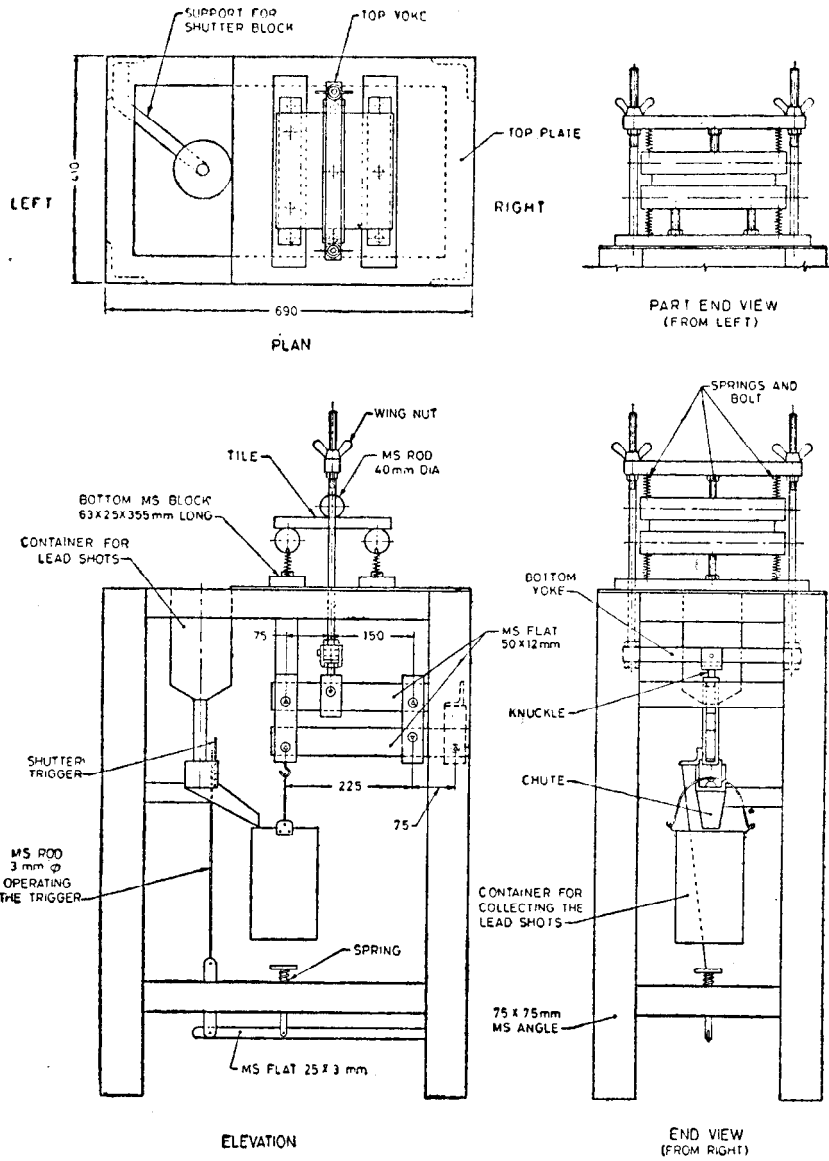

All dimensions in millimetres.

FIG. 4 TILE TESTING MACHINE

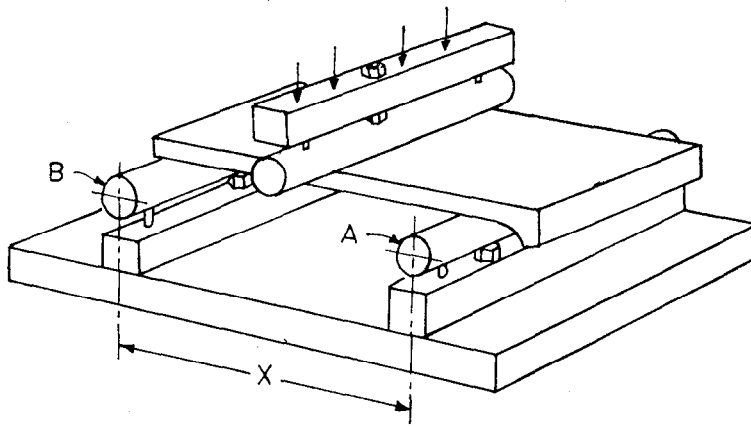

X = SPAN AS PER TILE SIZE

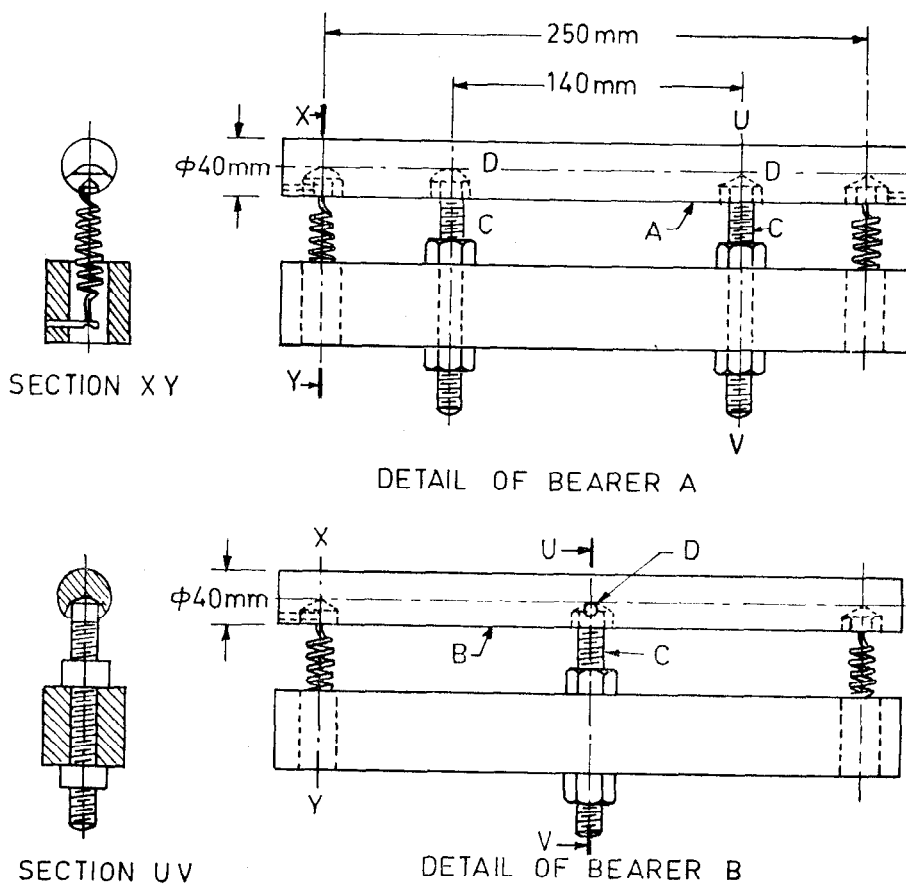

FIG. 5 ESSENTIALS OF APPARATUS FOR TRANSVERSE TEST

Standard Mark

The use of the Standard Mark is governed by the provisions of the *Bureau of Indian Standards Act, 1986* and the Rules and Regulations made thereunder. The Standard Mark on products covered by an Indian Standard conveys the assurance that they have been produced to comply with the requirements of that standard under a well defined system of inspection, testing and quality control which is devised and supervised by BIS and operated by the producer. Standard marked products are also continuously checked by BIS for conformity to that standard as a further safeguard. Details of conditions under which a licence for the use of the Standard Mark may be granted to manufacturers or producers may be obtained from the Bureau of Indian Standards.

Bureau of Indian Standards

BIS is a statutory institution established under the *Bureau of Indian Standards Act, 1986* to promote harmonious development of the activities of standardization, marking and quality certification of goods and attending to connected matters in the country.

Copyright

BIS has the copyright of all its publications. No part of these publications may be reproduced in any form without the prior permission in writing of BIS. This does not preclude the free use, in the course of implementing the standard, of necessary details, such as symbols and sizes, type or grade designations. Enquiries relating to copyright be addressed to the Director (Publications), BIS.

Revision of Indian Standards

Indian Standards are reviewed periodically and revised, when necessary and amendments, if any, are issued from time to time. Users of Indian Standards should ascertain that they are in possession of the latest amendments or edition. Comments on this Indian Standard may be sent to BIS giving the following reference :

Doc : No. CED 30 (4910)

Amendments Issued Since Publication

Amend No.	Date of Issue	Text Affected

BUREAU OF INDIAN STANDARDS

Headquarters:

Manak Bhavan, 9 Bahadur Shah Zafar Marg, New Delhi 110002
Telephones : 331 01 31, 331 13 75

Telegrams : Manaksanstha
(Common to all Offices)

Regional Offices:

	Telephone
Central : Manak Bhavan, 9 Bahadur Shah Zafar Marg NEW DELHI 110002	{ 331 01 31 331 13 75
Eastern : 1/14 C. I. T. Scheme VII M, V. I. P. Road, Maniktola CALCUTTA 700054	37 86 62
Northern : SCO 445-446, Sector 35-C, CHANDIGARH 160036	53 38 43
Southern : C. I. T. Campus, IV Cross Road, MADRAS 600113	235 02 16
Western : Manakalaya, E9 MIDC, Marol, Andheri (East) BOMBAY 400093	6 32 92 95

Branches : AHMADABAD. BANGALORE. BHOPAL. BHUBANESHWAR. COIMBATORE.
FARIDABAD. GHAZIABAD. GUWAHATI. HYDERABAD. JAIPUR. KANPUR.
LUCKNOW. PATNA. SRINAGAR. THIRUVANANTHAPURAM.